



HCI

Case Study - HCI cluster with 3 nodes deployment case

Version 5.8.3



Change Log

Date	Change Description
June 20, 2018	Version 5.8.3 document release.

CONTENT

Chapter 1 Background	4
Chapter 2 Customer Challenge/Demand	4
1 Difficult Expansion	4
2 Slow Time To Market	4
3 Complicated O&M	4
4 Low Resource Utilization	4
5 Hard for Service Innovation	5
Chapter 3 Solution	5
Chapter 4 Implement Steps	5
1 Resource List Collect	5
2 Network Topology Design	6
2.1 Design 1	6
2.2 Design 2	6
2.3 Design 3	7
3. Pre-installation	7
3.1 Active License.....	8
3.2 Build Cluster.....	9
3.3 Healthy Check.....	10
4. Employ Server to Customer’s Environment	11
4.1 Put server to the server rack.....	11
4.2 Change Management IP address	12
5. Migration Server Information Collect and Migration	13
5.1 Information Collection	13
5.2 Migration — P2V migration.....	14
Chapter 5 UAT	16

Chapter 1 Background

Digital transformation is the key strategy for enterprises. More and more new technologies and solutions in various industries.

The requirement for IT infrastructure is changing, there're two main points:

1. Improve IT efficiency: make development, test, launch faster to meet enterprise requirement. Save manpower by more automation adoption, cloud computing
2. Save cost: By adopting more and more technologies to save initial cost and avoid over-head investment.

Chapter 2 Customer Challenge/Demand

1 Difficult Expansion

Hardware-based infrastructure cannot provide dynamic resources for future business & data increasing requirement.

2 Slow Time To Market

Complicated architecture & compliances require long time provisioning for new service launch.

3 Complicated O&M

Impossible for unified management and maintenance since the infrastructure is from vary vendor with vary consoles.

4 Low Resource Utilization

High up-front investment with a lot of waste since one server only run one application. The utilization is only 15%.

5 Hard for Service Innovation

IT workload is consumed by infrastructure installation, provisioning, and maintenance. Rarely pay attention to service innovation.

Chapter 3 Solution

HCI is a category of scale-out, software integrated infrastructure that applies a modular approach to compute, network and storage on standard hardware, leveraging distributed, horizontal building blocks under united management.

Chapter 4 Implement Steps

1 Resource List Collect

Firstly, we should clearly collect whole resource list to do implement a plan. This customer has 3 aServer-2200 and switch, we should calculate its total resources and below is a referential table.

1. Physical Units List				
Type	Model	Quantity	Description	Remark
aServer	aServer-2200	3	CPU E5-2650v4* 2 (12C24T, 2.2GHZ), 128G (16G*8) Memory, 8*SATA/SAS disk slots, 128G OS disk, 6*GE, 2*10GE, 3*480G SSD cache disk and 6*4T HDD data disk	
Switch	Cisco2960	3	10/100/1000 Ethernet ports* 48, Uplink interfaces* 2SFP+, Cisco IOS Software image LAN Base, Available PoE power 740w.	
2. HCI Resource List				
Resource Type	Capacity	Remark		
CPU	72vCPU			
Memory	384G			
Storage	10T	2 Copies reserved 15%		
External Storage FC	None			
External Storage ISCSI	None			

2 Network Topology Design

HCI network interface includes management, storage, vxlan, and production interface. Different networks need to be designed to meet the business needs of customers.

2.1 Design 1

Different functional interfaces use separate switches that guarantee independent bandwidth and link-aggregation can be used to increase redundancy, but this design occupies multiple interface and switches.

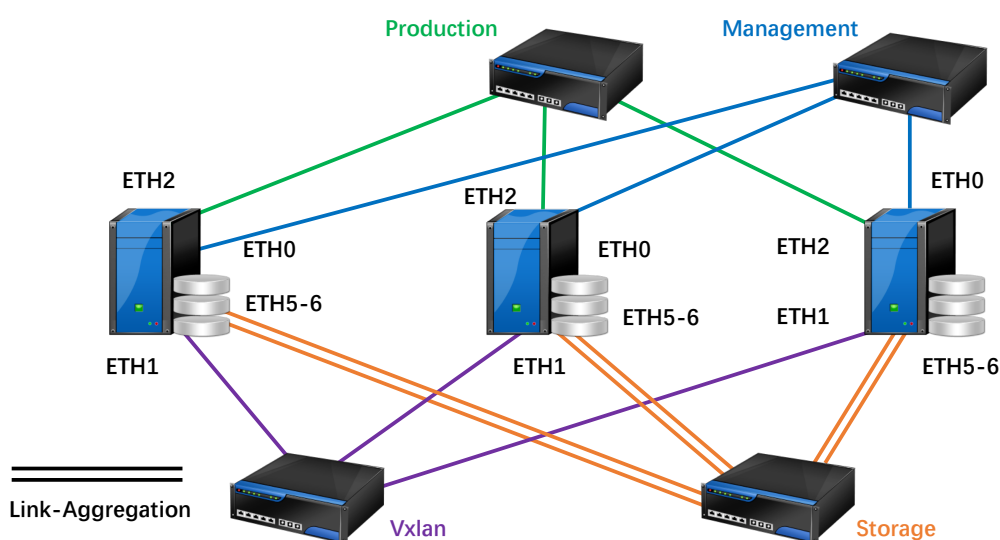

2.2 Design 2

Management and vxlan interface can be reused together due to traffic between internal VM is very small and link-aggregation make it redundancy.

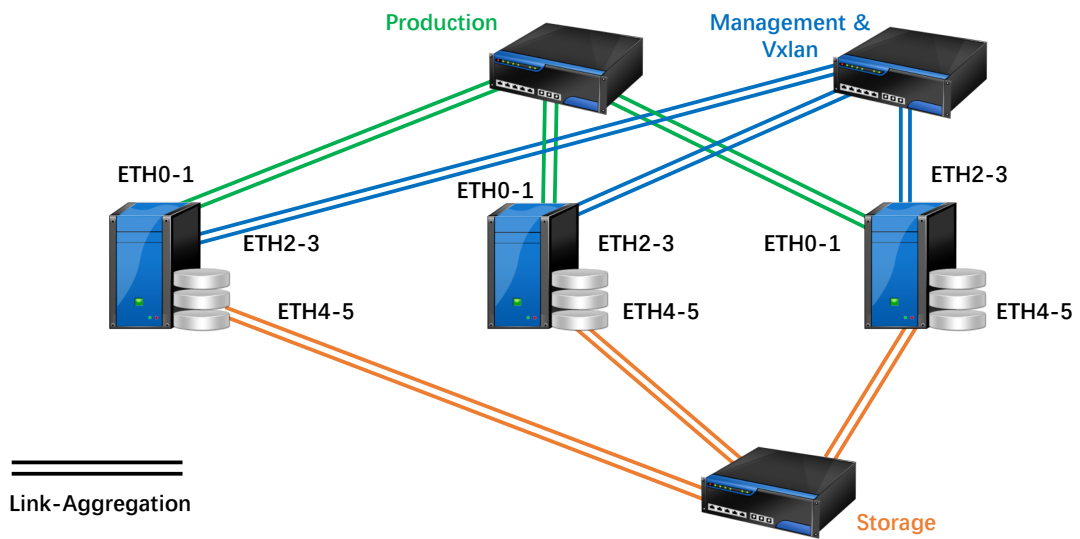

2.3 Design 3

For Storage network, we can use two switches to avoid a single point of failure. Below is the recommended network design for enterprise users. (you must confirm there is less vxlan traffic in customer's network environment)

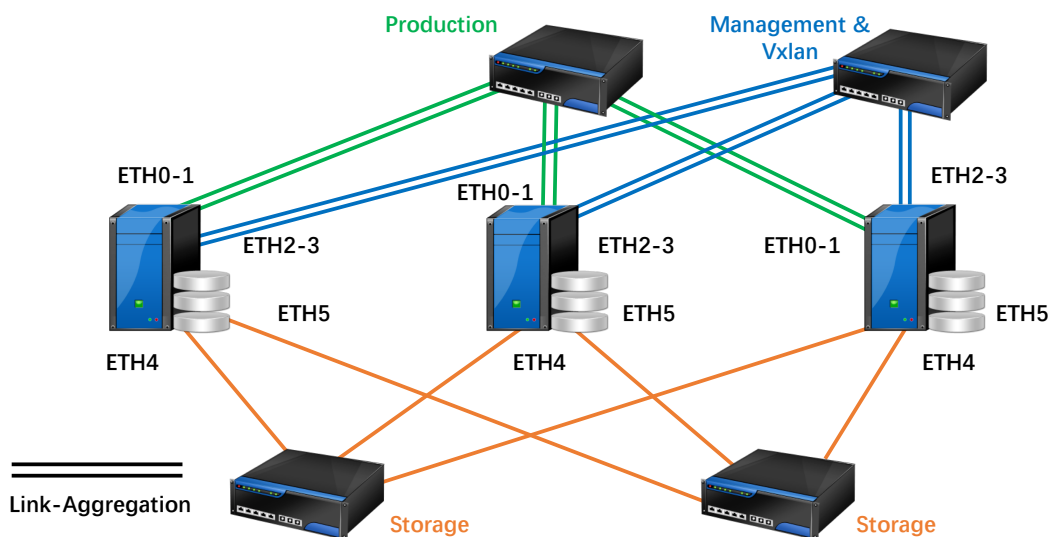

3. Pre-installation

3.1 Active License

Plug in the license key on any port of any server as below.



Synchronize server time with the correct local time.

SANGFOR HCI 5.3
Hyper-converged Infrastructure Platform

Home Compute Networking Storage Nodes System Health Check admin Super Admin

System > Date and Time

Date and Time

17:44:38
2017-10-11 Wednesday
(UTC+08:00) Irkutsk, Beijing
Change

Time Sync

Sync Time with NTP Server
Server: pool.ntp.org Save

Edit license serial number and check the feature is enabled.

SANGFOR HCI 5.3
Hyper-converged Infrastructure Platform

Home Compute Networking Storage Nodes System Health Check admin Super Admin

System > Licensing

Edition: **Pro** Enterprise Edition

License

Expiration Date: 2017-11-24
Update Service Expiration Date: 2017-11-23

Physical Resources

Host CPUs: 3 / 8

Virtual Machines

Max Running VMs: 65535
Max Cores Per VM: No limit
Memory Per VM: 255 GB

Virtual Storage

You may

Edit License Key

With this edition, you can:

- ✓ Add up to 64 nodes in a single cluster
- ✓ 10-6 PST customer service
- ✓ Simplify software update

USB key status is OK.
(Key ID: , Username:)

Basic License:	CUMMYML4-ET94N4EK-CSZ7BTJ4-E	✓
aSAN License:	bcvVGQAAAgAACAAQCAAAAAAAAA	✓
NGAF License:	SskmTJbuBDJTJW735CsvrtwxxFzkP4y	✓
IAM License:	4Z03CvAzBgst6loGDtIZBiYecyzt8efvZ	✓
ADC License:	S5SjZnqmGyVrh9FwPf8nZW85Uqkmv	✓

OK Cancel

3.2 Build Cluster

Login HCI platform and add a new node.

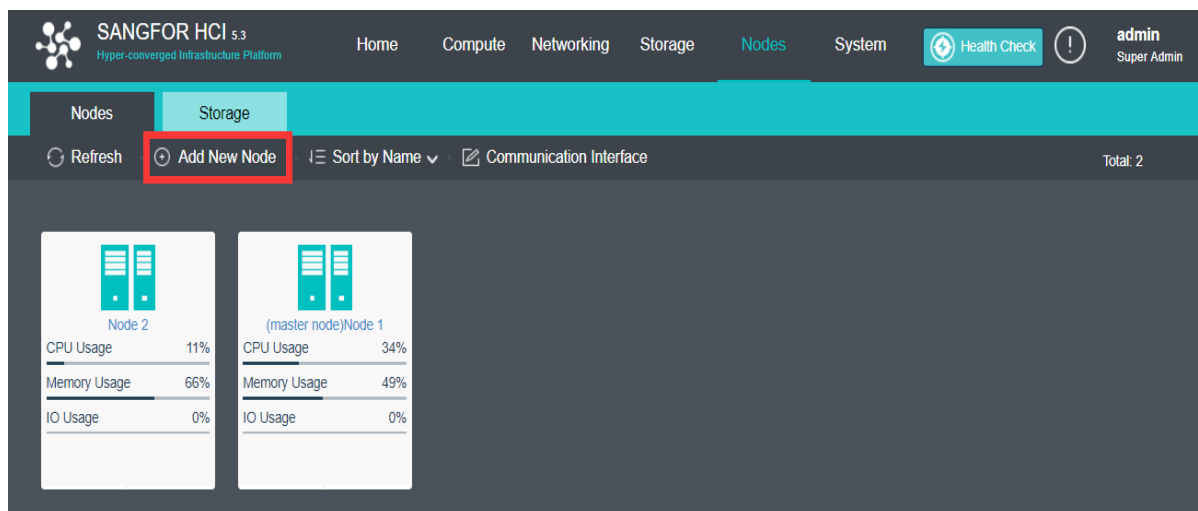

Set cluster IP and cluster name.

The 'Cluster' dialog box contains the following information:

Specify cluster IP address.

Cluster IP address is a virtual IP address specified by Sangfor HCI software for a given cluster, to achieve unified access and management. [Read More](#)

Cluster IP: 192.168.0.1

Netmask: 255.255.255.0

Cluster Name: HCI Cluster

Buttons: Save, Ignore

Select node auto detected nodes.

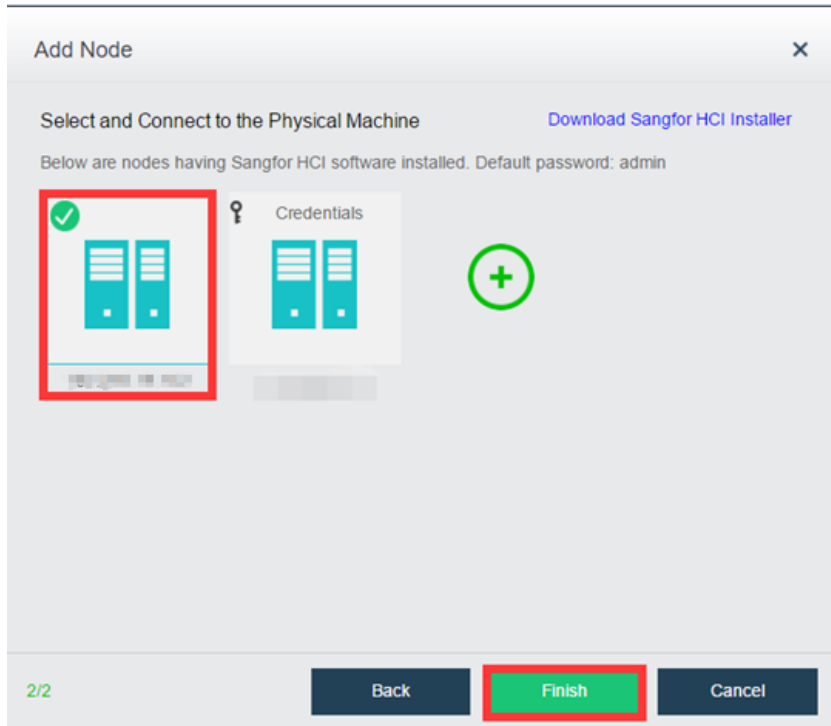

All cluster members all joined in.

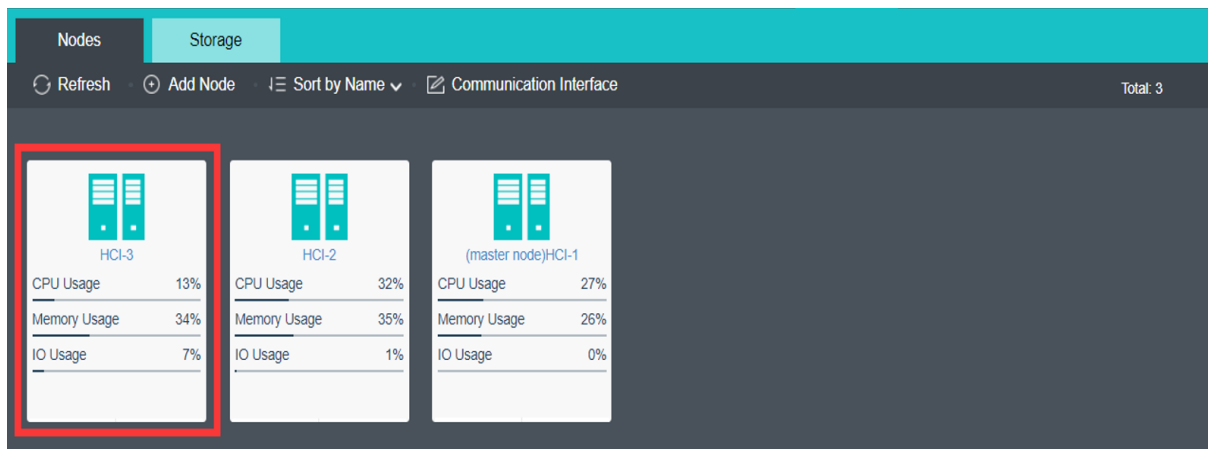

3.3 Healthy Check

Use system healthy check to analysis the status of HCI cluster.

Time Taken: 00:02:02 Progress: 100%

50

Task completed. 4 entity(ies) giving alarm, 1 entity(ies) failed Back Test Again

Warnings should be eliminated to ensure cluster performance and failures must be fixed ASAP to guarantee business continuity.

Results

Object	Virtual Storage	Read Caching Service	Write Caching Service	Host profile	Firewall Rules
192.200.17.201	✓	✓	✓	✓	✓
192.200.17.202	✓	✓	✓	✓	✓

Object	Disk profile
192.200.17.201 : 0...	⚠
192.200.17.201 : Di...	✓
192.200.17.201 : Di...	✓
192.200.17.201 : Di...	✓
192.200.17.201 : Di...	✓
192.200.17.201 : Di...	✓
192.200.17.202 : D...	✓
192.200.17.202 : D...	✓
192.200.17.202 : D...	✓
192.200.17.202 : D...	✓

Solution

Disk profile:
If the profile is not normal, follow the instructions or contact Sangfor Customer Service.

4. Employ Server to Customer's Environment

4.1 Put server to the server rack

Install server rack and below is the process:

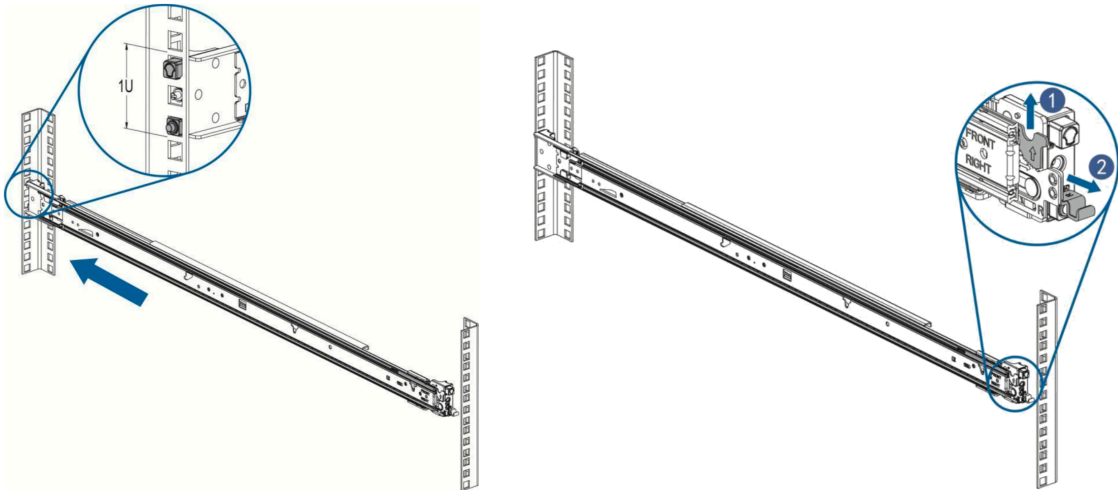

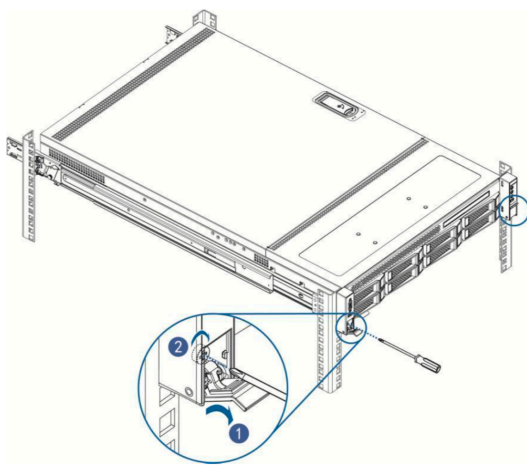
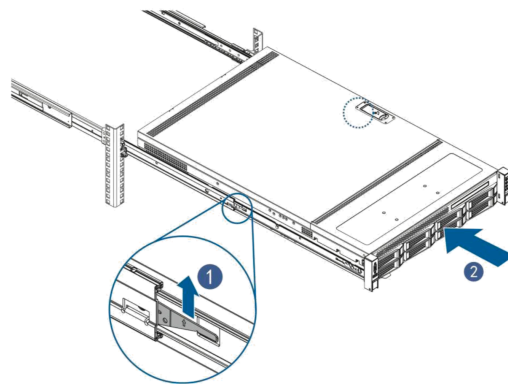
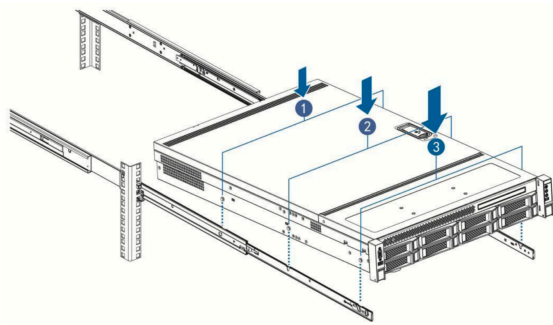
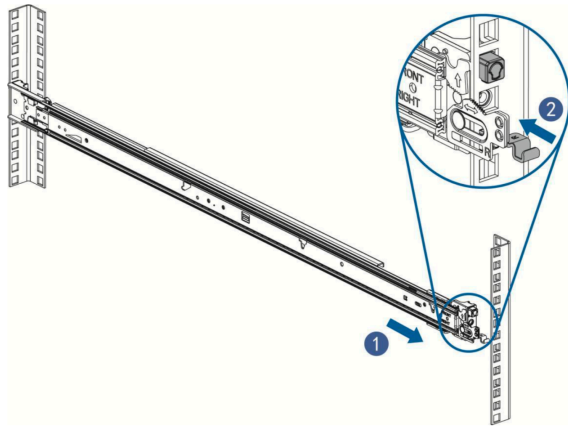

4.2 Change Management IP address

Must change IP address in the cluster as below:

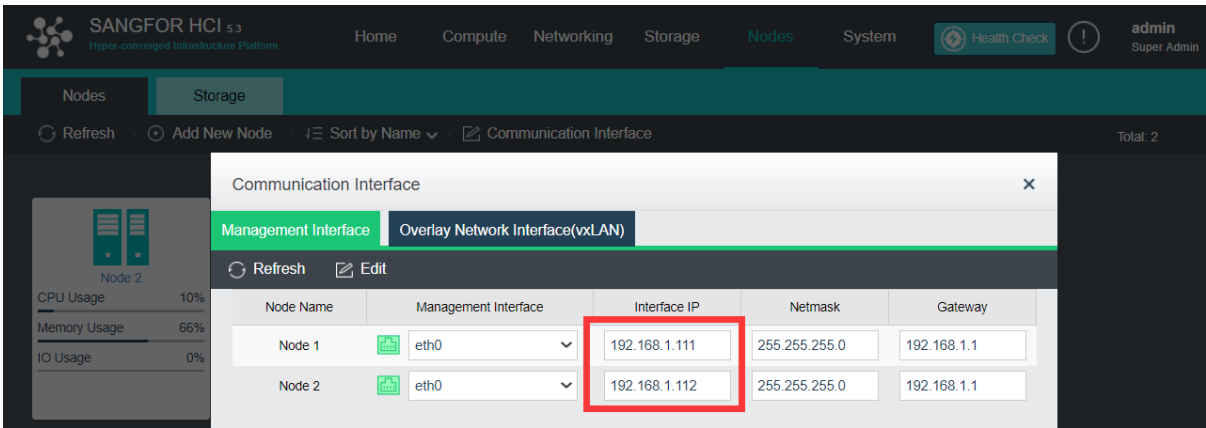
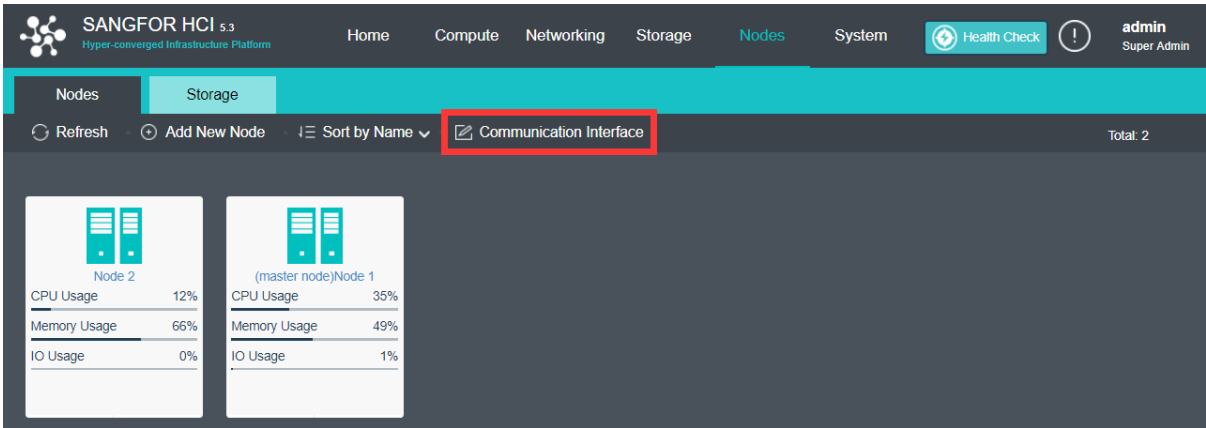

5. Migration Server Information Collect and Migration

5.1 Information Collection

Migration server information is very important for server migration. We should get the server system version, hardware usage, application type and migration type before migration. Better collect well the information before arrange on-site migration support.

Migration Server List				
Company Name :				
Person in Charge :				
Department/Location :				
Date :				
Hostname				
Operating System				
Version				
Hardware				
Model				
Number of CPU's Core				
RAM				
Database				
Total Storage Amount (C,D, E etc)				
RAID Type (0,1,5,10) or non-raid				
Applications running on server				
Any Backup Software				
Virtual or physical				
Remarks				
cpu / type				
Status				
Migration Type				
Priority				
Install Date				

5.2 Migration — P2V migration

Prepare bootable ISO firmware

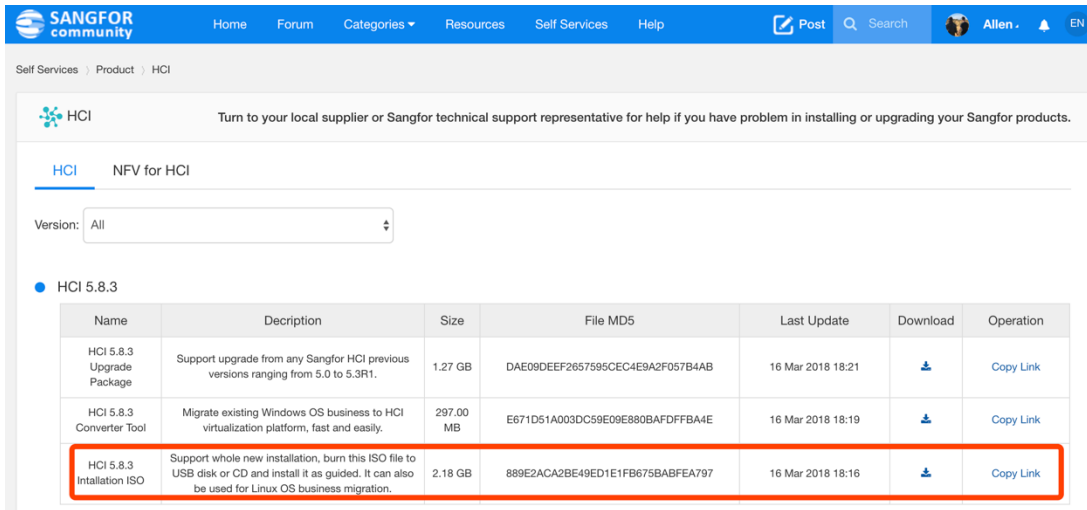

The screenshot shows the Sangfor Community forum page for HCI. The forum post is titled "HCI" and includes a sub-section for "HCI 5.8.3". A table lists three download options for HCI 5.8.3, with the "Installation ISO" option highlighted by a red box.

Name	Description	Size	File MD5	Last Update	Download	Operation
HCI 5.8.3 Upgrade Package	Support upgrade from any Sangfor HCI previous versions ranging from 5.0 to 5.3R1.	1.27 GB	DAE09DEEF2657595CEC4E9A2F057B4AB	16 Mar 2018 18:21	Download	Copy Link
HCI 5.8.3 Converter Tool	Migrate existing Windows OS business to HCI virtualization platform, fast and easily.	297.00 MB	E671D51A003DC59E09E880BAFDFFBA4E	16 Mar 2018 18:19	Download	Copy Link
HCI 5.8.3 Installation ISO	Support whole new installation, burn this ISO file to USB disk or CD and install it as guided. It can also be used for Linux OS business migration.	2.18 GB	889E2ACA2BE49ED1E1FB675BABFEA797	16 Mar 2018 18:16	Download	Copy Link

Use UltraISO to create bootable pen drive.

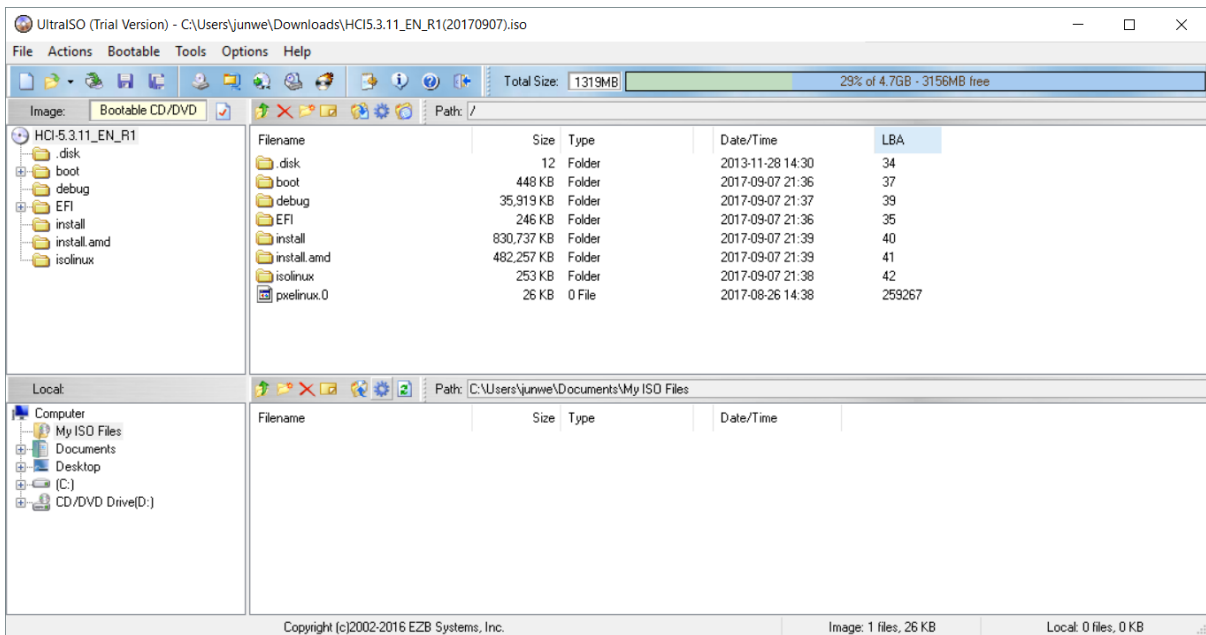

The screenshot shows the UltraISO software interface. The main window displays the file structure of the "HCI-5.3.11_EN_R1" ISO file. The file list includes folders for .disk, boot, debug, EFI, install, install.amd, and isolinux, along with a pxelinux.0 file. The software is set to create a bootable CD/DVD image.

Filename	Size	Type	Date/Time	LBA
.disk	12	Folder	2013-11-28 14:30	34
boot	448 KB	Folder	2017-09-07 21:36	37
debug	35,919 KB	Folder	2017-09-07 21:37	39
EFI	246 KB	Folder	2017-09-07 21:36	35
install	830,737 KB	Folder	2017-09-07 21:39	40
install.amd	482,257 KB	Folder	2017-09-07 21:39	41
isolinux	253 KB	Folder	2017-09-07 21:38	42
pxelinux.0	26 KB	0 File	2017-08-26 14:38	259267

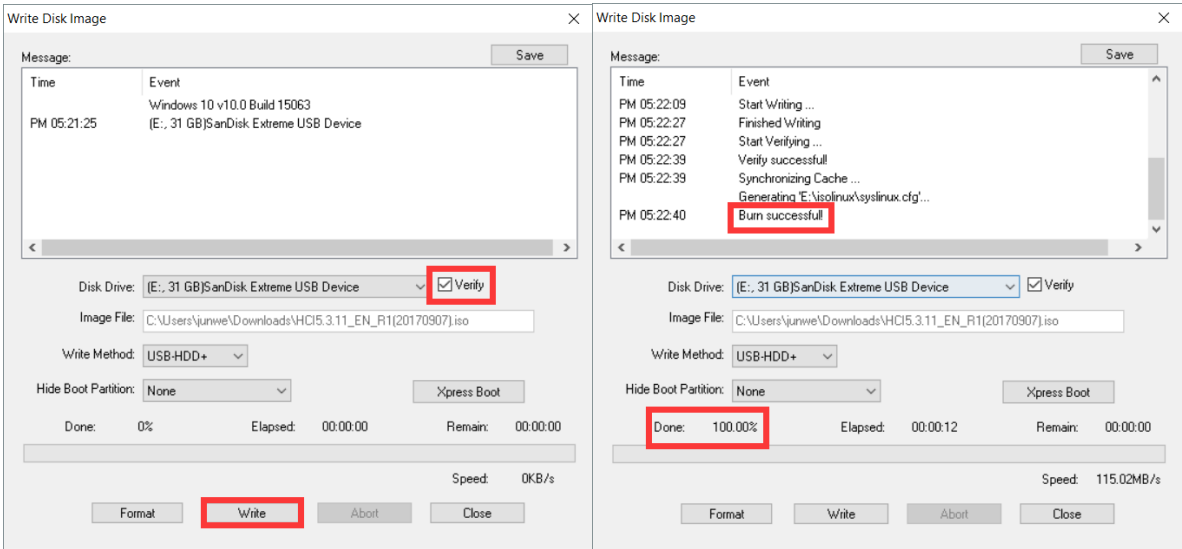
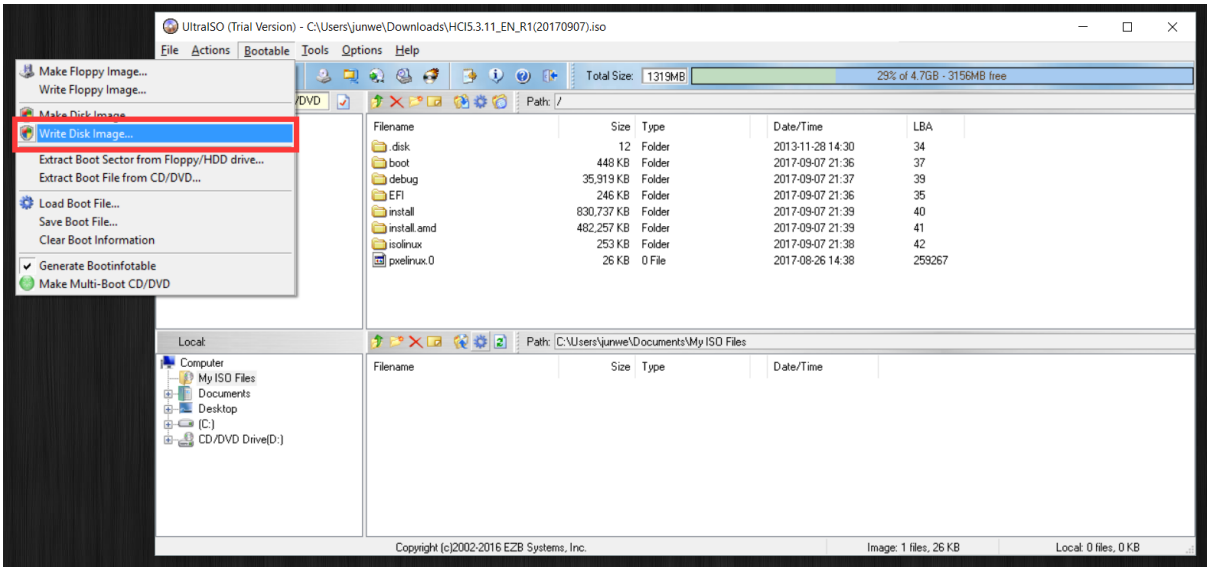

Power off physical server and boot with bootable pen drive, select “Migrate this machine to Sangfor HCI”

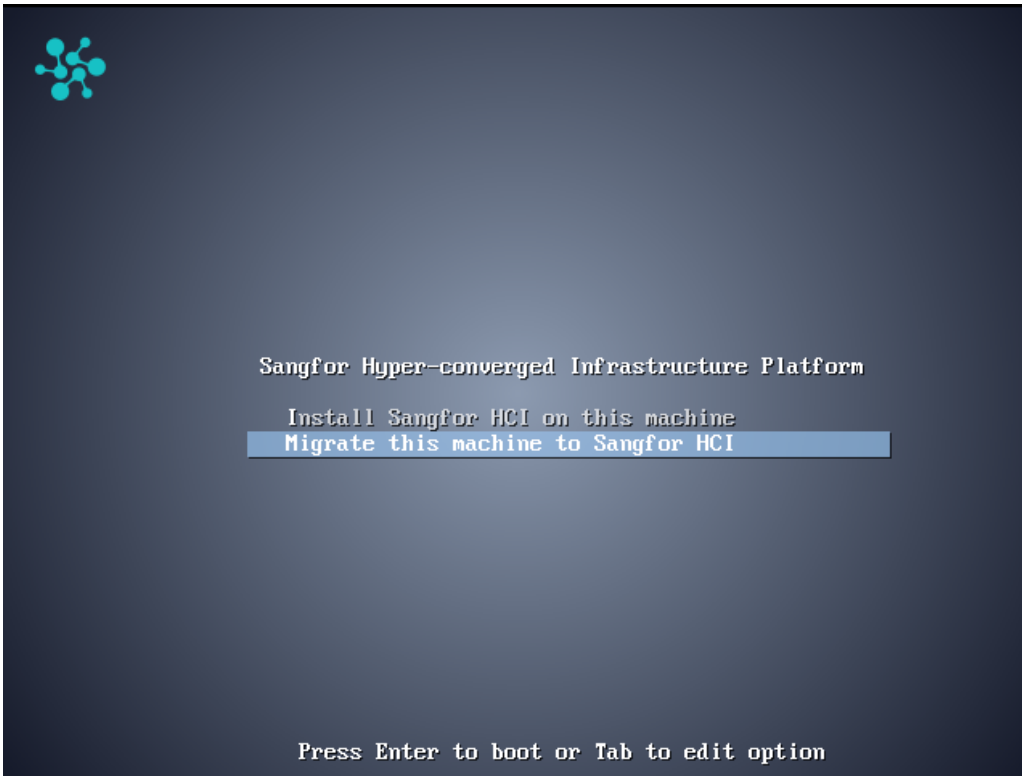

Chapter 5 UAT

Meeting with the customer to set user acceptance test items and do the test one by one. Below is part of UAT.

▪ **Test Scenario 5 – Management Features**

This test scenario is going to show a single management tool to perform start of the day tasks, which currently we are executing from vCenter Console.

▪ **5.1 Management Features**

Task #	Task	Notes	PIC	Pass/Fail
	Most of these details will be reported through the SANGFOR Management Console. Demonstrate the changes during previous testing			
5.1.1	View Equipment Firmware (Server, Storage, Network Components).			
5.1.2	View Server detail hardware (e.g. NIC models, DIMM models and count, CPU model etc.)			
5.1.4	Manage and update firmware inventory from SANGFOR Management Console			
5.1.5	View graphical representation of storage from SANGFOR Management Console.			
5.1.6	Take automated pre-emptive action on pending performance issues using SANGFOR Management Console.			

↵

↵

Prepared By,

Name:

Title:

Comment:

Signature:

Date:



Copyright © SANGFOR Technologies Inc. All rights reserved.

No part of this document may be reproduced or transmitted in any form or by any means without prior written consent of SANGFOR Technologies Inc.

SANGFOR is the trademark of SANGFOR Technologies Inc. All other trademarks and trade names mentioned in this document are the property of their respective holders. Every effort has been made in the preparation of this document to ensure accuracy of the contents, but all statements, information, and recommendations in this document do not constitute a warranty of any kind, express or implied.

The information in this document is subject to change without notice.

To obtain the latest version, contact the international service center of SANGFOR Technologies Inc

